

Audio Mixer for Broadcasting



**THE BEST VALUE IN
THE BROADCASTING
MARKET TODAY**

In 1996, at NAB, AEQ launched the affordable and 'Cool Stuff' award-winning BC-300 audio mixer for broadcasting.

This console was designed to offer professional technology and features, capable of delivering the highest sound quality while working 24 hours a day 7 days a week at an affordable price suitable for small and medium-sized radio stations.

In relation to the well known BC-300 consoles, the BRAVO console introduction is: **a leap from good to excellent.**

Outstanding Value!

- ➔ 2 Telephone Hybrids Built-in.
- ➔ 10-Watts Power Amplifier Built-in.
- ➔ 2 Stereo Busses Program + Audition.
- ➔ CUE Stereo Speakers.
- ➔ 2 VU meters Selectable Master or "Select" with adjustable viewing angle.
- ➔ Built-in Talk-back microphone with send to telephone and studio headphones.
- ➔ Universal Power Supply 100-240 V. 100 VA.
- ➔ Flexible design for Tabletop or Countersink into studio furniture.

Just some of the features the BRAVO has as standard:

- 4 mic - line channels.
- 8 dual stereo line channels.
- 1 dual telephone channel with 2 hybrids included.
- 2 stereo programme buses.
- Stereo CUE bus with built-in loudspeakers.
- Stereo monitor output with built-in power amplifier.
- Headphone output.
- ON-AIR signalling and automatic monitor cut-off.



Bravo to countersink

DIMENSIONS

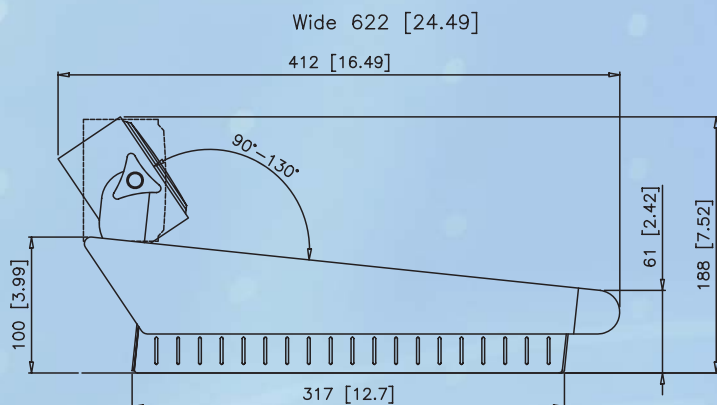

PLACED ON A TABLE
Dimensions in mm [inches]

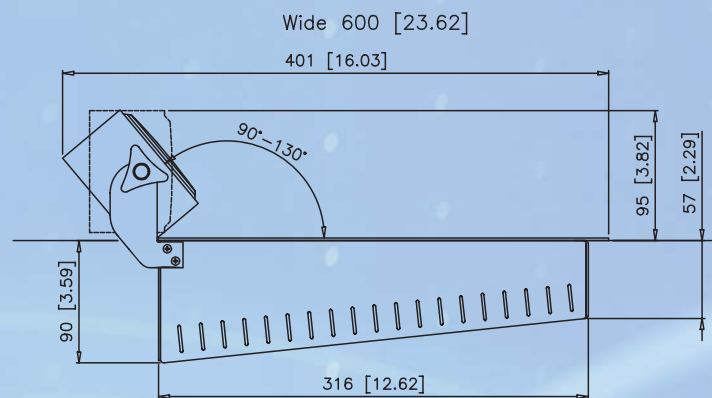

SUNK INTO CUSTOM WOODWORK
Dimensions in mm [inches]

BRAVO TECHNICAL SPECIFICATIONS

INPUT CHANNELS DESCRIPTION:

4 Mic/Line channels:

- Electronically balanced mic input.
- Asymmetrical line input.
- Mic/line switch.
- 100 mm VCA fader.
- CUE button.
- Telephone send button.
- Master and Audition send buttons.
- Channel ON/OFF button.
- XLR female (Mic.) and RCA phono (Line) connectors.
- Fine adjustment for input gain.

8 Stereo Line Channels:

- Asymmetrical stereo inputs.
- Line input A / B switch.
- 100mm VCA fader.
- CUE button.
- Telephone send button.
- Master and Audition send buttons.
- Channel ON/OFF button.
- RCA phono connectors.
- Fine adjustment for input gain.

OUTPUT FEATURES DESCRIPTION:

- Program + Audition transformer balanced stereo outputs (XLR male + Hartmann), with level preset.
- Balanced Control Room Monitor stereo output with control level.
- 10 W stereo output for Studio Monitor. Program / Audition / CUE selectable.
- 10-W stereo loudspeakers on VU meter bridge.
- Three stereo recording outputs (RCA connector) with level preset.

AUXILIARY INPUT FUNCTIONS:

- External stereo input with level preset. RCA connectors. Internal jumpers for Programme/CUE send.

TELEPHONE CHANNEL:

- Two telephone line Inputs (RJ11).
- Two built-in telephone analogue hybrids with C and R control. Switchable to use external hybrid with RJ11 and strip connectors for telephone handset.
- Program/Audition/CUE send.
- Volume pot.
- Return from input channels or talkback
- Incoming call buzzer and LED indicator.
- Hold switch.

OTHER FUNCTIONS

- Talkback microphone with send buttons to telephone and studio headphones.
- DC Studio and cue light signalling. Strip connector output.
- Two stereo VU-meters: Program and Select.
- Studio monitors muting.

POWER SUPPLY:

Autorange 100-240 V. 100 VA 50-60 Hz.

APPROX WEIGHT:

10 KG (22 lbs).